



www.bridgendbeekeepers.co.uk

Bridgend and District Beekeepers Association

Volume 17, Issue 7.

July 2010

Are You Doing This?

- If the weather gets wet make sure you get your supers on for the Balsam
- Book the extraction equipment *EARLY* and return it on the *DATE and TIME agreed*

Inside this issue:

Solar Wax Extractor Plans 2

Preserving Beehives with Cuprinol 2

Rendering and Purifying Beeswax 3

For Sale 4

BeeBrain 4

Association News

Many thanks to Phillip and Phillipa who went to a great deal of trouble to organize an Association Meeting at their Apiary only to find 2 people turned up! By all accounts you missed a fabulous evening.

Members sitting the Basic Beekeeping Exam should be shortly contacted by Dinah Sweet regarding the date. Apologies for the delay, it seems the WBKA has no agreed policy for arranging these exams! If you have not heard from Dinah by Friday 9th. July PLEASE get back to me.

Janet has been off to Caerau teaching schoolchildren all about bees, This is a joint project between Bridgend Beekeepers and Communities First in Caerau. below <http://community.nationaltheatrewales.org/profiles/blogs/theatr-na-nog-we-need-bees> The project is a play for children and workshops. The organizer is looking for outdoor venues for the play in Bridgend Borough e.g. allotments, etc. Contact Sue if you can help. Happy Beekeeping



Meetings

Group A	Group B	Group C	All Members
20th June Beginners		4th July Beginners	27th June open to all Members
	18th July Beginners	25th July Beginners	11th July open to all Members
1st August Beginners	8th August Beginners		15th Aug Family Day All Welcome

Meet 10am Beleaf Nursery, Bryngarw Park,
Bridgend

Greg Nuttgens
invites you to his
Apiary in
**The Walled
Garden, Tythegston**
July 21st. 2010,
6.30pm
Contact Greg
01656 773501

SOLAR WAX EXTRACTOR

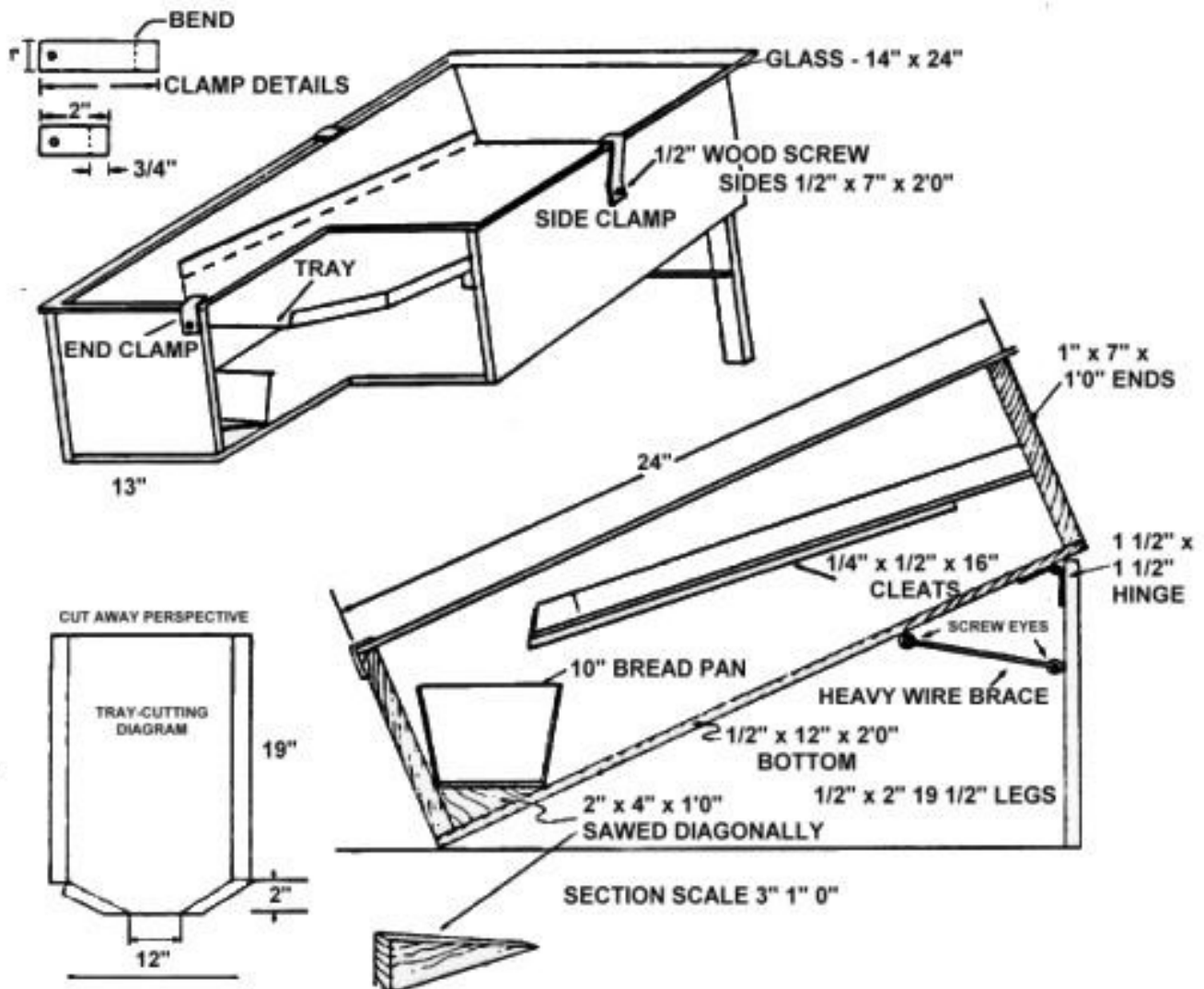

Preserving Beehives with Cuprinol

Due to EU legislation Cuprinol has had to change the active ingredients which are used in wood preservers. New formulations have not been tested for use on beehives and as a result Cuprinol cannot recommend any of its wood preservers on Beehives.

Cuprinol go onto say, when used alone, conventional paint will protect against rain and water from the outside, but it does not prevent decay or absorption of water from the inside. Paint will prevent moisture drying out through the outside surface and so may result in wood being wetter than if unpainted.

It may be better to leave beehives untreated and uncoated to allow maximum drying out and reducing the potential for decay.



Rendering and Purifying Beeswax

As part of the normal beekeeping year, beekeepers accumulate wax from replacing old brood frames and from cappings at extraction time.

Brood Frames

Each year it is recommended that a beekeeper replaces a third of the frames in the brood box. It is important that the frames are replaced for several reasons.

- Old frames may harbour disease in the form of spores and fungi
- Cells in old frames become smaller in size resulting in stunted bees.

Old frames are said to encourage swarming.

Brood frames will be darker in colour and contain debris from brood rearing. The resulting wax is usually mixed with capping to make new foundation; either making it yourself on a small scale or in part exchange for commercial packs of foundation.

Cappings

These are produced as a by product of the extraction process. They are usually light in colour, have little debris imbedded and of fine quality. When rendered they are used for cosmetics, fine candles and moulded blocks for fishermen and stitchers.

Common Methods of Extraction

Wax is a very valuable commodity. It is important that your rendering process doesn't waste wax or damage the quality. Whatever method of extracting you decide on, always wash the wax in cold water to get rid of as much honey as possible before you start extracting.

- Hot Water Extraction
- Steam Wax Extractor
- Solar Wax Extractor

Hot Water Extraction

This is the most common method used by beekeeper worldwide. It is cheap, easy to monitor and requires no specialist equipment. Use Stainless Steel, Aluminium or Copper equipment only. **Do not use** Zinc, Pewter, Tinplate or Galvanized Iron as these metals will darken the wax.

Use rainwater **NOT tap water**, as tap water can make your wax 'spongy'.

Put your wax into an old pair of tights, weight the tights and submerge in a large pan of clean water or an old clothes boiler. Bring to the boil. The wax will filter through the tights and float to the surface leaving most of the debris behind. Once all the wax has melted turn off the heat. As the water and wax cools, the wax will solidify into a block on top of the water.

Steam Wax Extractor

Here a basket is placed into the main part of the tank and filled with wax. There is a communicating outer tank filled with water. The water is heated to produce the steam. The steam melts the wax. The wax flows out of a nozzle into a collecting bowl. The debris is collected in the basket.

Can be difficult to clean, and is expensive to buy. Members are able to borrow a steam extractor from the Association.

Solar Wax Extractor

Eco friendly as it uses the sun's heat to melt the wax. Expensive to buy but relatively easy to make from scrap wood and double glazed glass. In Wales will only be suitable for the summer months!

Wax is placed in a double glazed and insulated box. The box is propped on an angle and pointed into the sun. The wax melts and runs down the metal strip through a metal filter into a collecting vessel. If the sun is too strong you run the risk of overheating the wax, *even setting it alight*. If the sun is not out, it doesn't work.

The only method that can sterilize frames if you can get the box gets hot enough. Solar Wax Extractors produce the cleanest wax.

Further Rendering and Purifying.

Whatever method you use to extract your wax except solar, you now need to further render the wax to remove any residual debris, just repeat the process until you achieve the desired quality. You can reduce the debris trapped in the wax by cooling the wax SLOWLY.

BRIDGEND AND DISTRICT BEEKEEPERS
ASSOCIATION

www.bridgendbeekeepers.co.uk

Sue Verran
SECRETARY

TY MEL
Maesteg Road
Coytrahen
Bridgend
CF32 0EE
01656 729699
secretary@bridgendbeekeepers.co.uk
*All correspondence, Newsletter
Equipment Loan*

John Verran
President

01656 724249
John.verran@btinternet.com
*All Aspects of Beekeeping
Expert Bee Disease Advice*

Mike Pett
Chairman

01656 658963
mpett@talktalk.net
*All Aspects of Beekeeping
Association Shop*

Craig Brocklebank
Apiary Manager

01656 730582
c_brocklebank@sky.com
All Association Apiary Events

Andy Poulter
Education Officer

ADP@pjpuk.fsbusiness.co.uk
*Beginners Classes
Master Classes*

Angela Lithgow MacLean
WEB Master/Librarian

01639 710293
library@bridgendbeekeepers.co.uk
*Library Loans
Web Page*

Janet Martin
Treasurer

01443 436699
treasurer@bridgendbeekeepers.co.uk

**Meeting cancelled? ring 07812187301 for
answer phone message**

Beebrain 2009

S	E	L
G	E	T
A	I	L

- How many words can you make out of the 9 letters above?
- Each word must contain the centre letter (yellow)
- Put all nine letters together to form one nine letter word associated with Beekeeping.

Last months nine letter word: Monitored

Bees For Sale

6 frame Nucleus Hives

£120

(Just coming ready for sale)

Contact John Verran

01656 729699

John.verran@btinternet.com

WBC Hive Parts for Sale

roofs, lifts, brood boxes, supers, queen excluders, crown boards, ekes, mesh floor.

Please contact Greg Nuttgens on 01656 773501 or
07896 570263

National Parts for Sale

Available at The Association Apiary
July 11 at 10am